



## Electric Chain Hoist

### Series

- BLFD-008-1
- BLFD-012-1
- BLFD-016-1
- BLFD-024-1
- BLFD-032-2
- BLFD-048-2



**CHENG DAY** MACHINERY WORKS CO., LTD.

# SAFETY-IMPORTANT

The use of any hoist and trolley presents some risk of personal injury or property damage.

That risk is greatly increased if proper instructions and warnings are not followed. Before using this hoist, each user should become thoroughly familiar with all warnings, instructions and recommendations herein.



THIS SYMBOL POINTS OUT IMPORTANT SAFETY INSTRUCTIONS WHICH IF NOT FOLLOWED COULD ENDANGER THE PERSONAL SAFETY AND/OR PROPERTY OF YOURSELF AND OTHERS. READ AND FOLLOW ALL INSTRUCTIONS IN THIS MANUAL AND ANY PROVIDED WITH THE EQUIPMENT BEFORE ATTEMPTING TO OPERATE YOUR "U-MEGA" ELECTRIC CHAIN HOIST.



# CONTENTS

---

Safety-Important .....	1
1.Foreword .....	3
2.Main Specification .....	4
2.1 Specification .....	4
2.2 Mechanical Classification (Grade) and Life .....	5
2.3 Safety Device .....	6
2.4 Specification and Dimensions .....	7
3.Safety Rules .....	8
4.Installation .....	10
4.1 Unpacking Information .....	10
4.2 Voltage .....	10
4.3 Installation .....	11
5.Operation .....	12
6.Maintenance and Inspection .....	13
6.1 Maintenance .....	13
6.2 Inspection .....	13
7.Troubleshooting .....	16
7.1 Wiring Diagrams .....	16
7.2 Troubleshooting and Remedial Action .....	19
8.Drawings and Parts List .....	20
9.Declaration Of Conformity .....	29

---

## 1.FOREWORD

This manual contains important information to help you properly install, operate and maintain the U-MEGA electric chain hoist for maximum performance, economy and safety.

Please study its contents thoroughly before putting the electric Chain hoist into operation. By practicing correct operation, procedures and by carrying out the preventative maintenance recommendations, you will be assured of dependable service. In order to help us to supply correct spare parts quickly, please always specify,

- (1) Hoist model
- (2) Serial number
- (3) Part number, plus the description.

We will have your trust of Cheng Day's long term satisfactory service as our belief.

Should you have any queries, please contact:

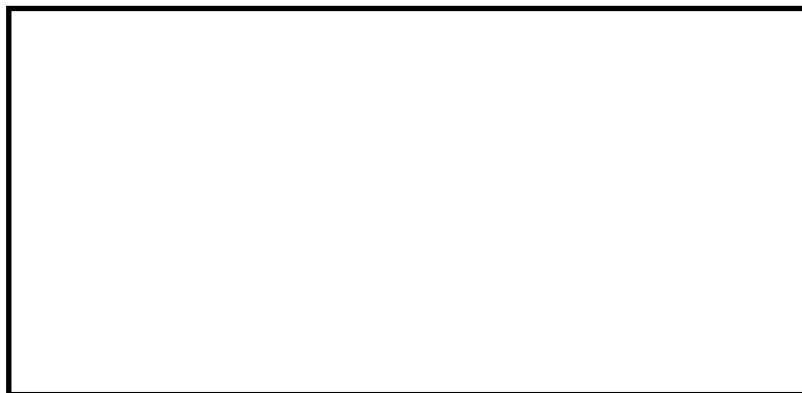

( Please ask for a company's stamp from your local agent)

## 2. MAIN SPECIFICATIONS

### 2.1 Specifications

The following specifications are common to all U-MEGA electric chain hoists.

**Table 2-1 Specifications**

Item		Detail	
Working temperature range (°C)		-5 to +40	
Working humidity range (%)		85 or less	
Protection	Hoist	IP 54	
	Push button Switch	IP 65	
Electric power supply		Single phase, 100V~240V(+/-10%), 50HZ/60HZ	
Noise level (dB)		81	
Series No.	WLL (working load limit) (kg)	Nominal diameter (mm)	Pitch (mm)
BLFD-008	80kg	4.0	12
BLFD-012	120 kg	4.0	12
BLFD-016	160 kg	4.0	12
BLFD-024	240 kg	4.0	12
BLFD-032	320 kg	4.0	12
BLFD-048	480 kg	4.0	12

Remarks: (1) Contact an authorized U-MEGA dealer for information on using the hoist outside the working temperature or humidity range.

(2) Intended use : This hoist has been designed for vertically lifting and lowering load under normal atmospheric conditions of work place.

(3) Noise levels were measured at a distance of 1m horizontally from the hoists during normal operation.

## 2.2 Mechanical Classification (Grade) and Lift

Safety and life for electric chain hoists are guaranteed only when the said equipment is operated in accordance with the prescribed grade.

U-MEGA BLFD single phase electric chain hoists have been designed for grade

1Am in the FEM regulations (FEM 9.511).Details are provided in Table 2-2.

Average daily operating time and total operating time are determined by load distribution.

Table 2-2 Mechanical classification

Load Spectrum (Load distribution)	Definitions	Cubic mean value	Average daily operating time(h)	Total operating time(h)
1 (light)	Mechanisms or parts thereof, usually subject to very small loads and in exceptional cases only to maximum loads.	$k \leq 0.50$	2 - 4	6300
2 (medium)	Mechanisms or parts thereof, usually subject to small loads but rather often to maximum loads.	$0.50 < k \leq 0.63$	1 - 2	3200
3 (heavy)	Mechanisms or parts thereof, usually subject to medium loads but frequently to maximum loads.	$0.63 < k \leq 0.80$	0.5 - 1	1600
4 (very heavy)	Mechanisms or parts thereof, usually subject to maximum of almost maximum loads.	$0.80 < k \leq 1.00$	0.25 - 0.5	800

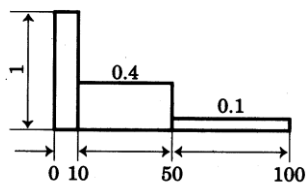

% operating time  
Load spectrum 1

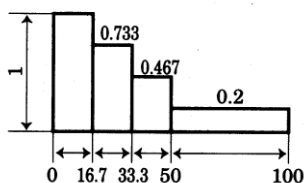

% operating time  
Load spectrum 2

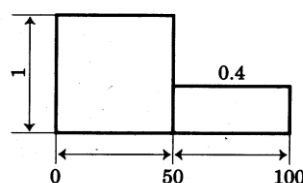

% operating time  
Load spectrum 3

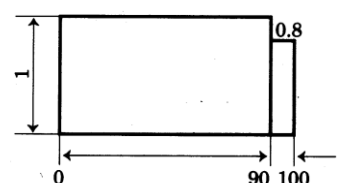

% operating time  
Load spectrum 4

## 2.3 Safety Devices

### (1) Mechanical load brake

The mechanical load brake can hold a full capacity load independent of motor brake. This brake assures that load does not accelerate while being lowered.

### (2) Hook and hook latch

The hook is drop-forged from high tensile steel and heat treated for strength and toughness.

The button hook is capable of 360° swivel and fitted with safety latch to ensure safe lifting.

### (3) Limit Switches

Upper and lower limit switches are fitted for switching off power automatically in case of over lifting or over lowering.

### (4) Emergency stop device

This button is used to stop the hoist in an emergency situation. It is red, mushroom type button, located in the uppermost position on the pendant. When pressed, power to the equipment is switch off and button locks automatically. Turning it to the right will release the lock and to enable re-starting.

### (5) Shock protection

It cannot run, when you push the button for anti-direction in "UP" or "DOWN" running. You must wait over 1 second.

## 2.4 Specification and Dimensions

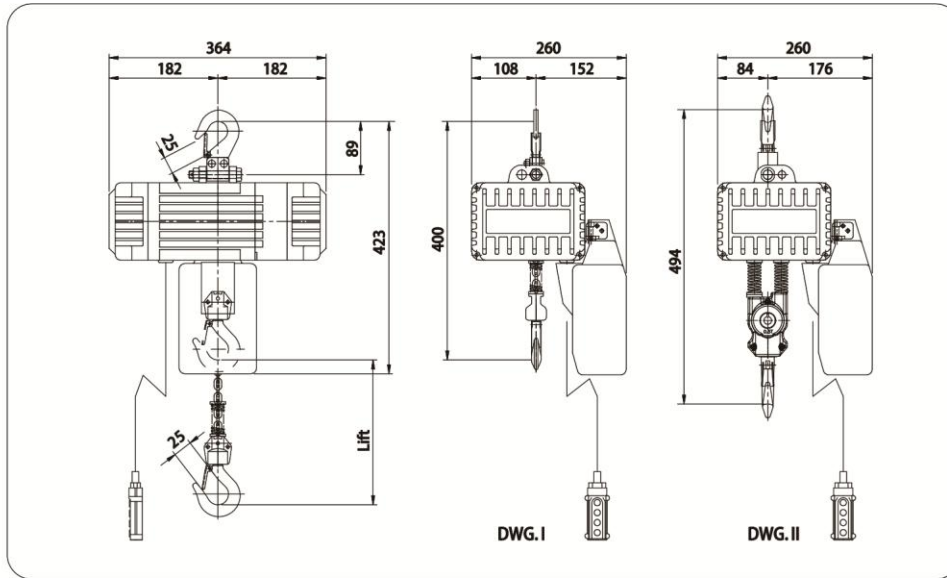

Rated Power Source	Single Phase , 100 V~ 240V ( +/-10% ) , 50Hz / 60Hz													
Model	DWG.	Rated Load (kg)	Motor Output (W)	Time Rating (min)	Intermittent Duty		Rated Current (A)	Lifting Speed (m/min)	Standard Lift (m)	Push Button Cord (m)	Load Chain Diameter (mm)	Fall no.	N.W. / G.W. (kg)	
					%ED	Max.Starting Frequency (times/hr)							3m	6m
BLFD-008	I	80	300	15	30	180	6.0 (110V) 3.0 (220V)	0 ~ 4.8/18	3	3	4X12	1	16.5/ 19.5	17.5/ 20.6
BLFD-012	I	120						0 ~ 3.2/12.5						
BLFD-016	I	160	600	15	30	180	10.0 (110V) 5.0 (220V)	0 ~ 4.8/18	3	3	4X12	1	16.5/ 19.5	17.5/ 20.6
BLFD-024	I	240						0 ~ 3.2/12.5						
BLFD-032	II	320	600	15	30	180	10.0 (110V) 5.0 (220V)	0 ~ 2.4/9	3	3	4X12	2	19.4/ 22.4	21.5/ 24.5
BLFD-048	II	480						0 ~ 1.6/6.3						

※ Packing ( L x W x H ) : 500 x 390 x 205 ( mm )

※ Maximum Push Button Cable Length 20m



### 3. SAFETY RULES

#### **DANGER**

The hoist herein is not designed for, and should not be used for, lifting, supporting, or transporting personnel. Any modifications to upgrade, re-rate, or otherwise alter the hoist equipment must be authorized by either the original manufacturer or a qualified professional engineer.

#### **DANGER**

Do not use the hoist in explosive atmosphere.

- (1) Prior to each lifting operation, it is essential to make sure that:
  - (a) the correct lifting sling is being used.
  - (b) the lifting sling is located in the hook as shown below (Illust. 2) and that a safety latch has been fitted.

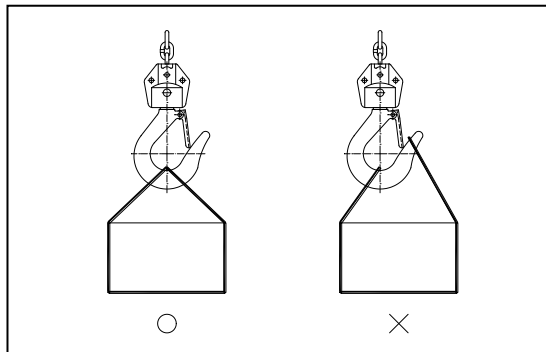

Illust. 2

- (c) the object to be hoisted is well secured for direct lifting (a proper lifting frame or apparatus is strongly recommended for direct lifting .)
- (2) Firm and steady button operation is required, never push the button switch intermittently.
- (3) Always avoid excessive inching operation.
- (4) Always make sure the hoist motor completely stops before reversing.
- (5) Always leave the pendant button switch cable and bottom hook load chain vertically static after completion of operation, never leave them at any position, which may allow them swing or slip.

(6) Sling must be applied to load evenly and centrally to ensure correct balance.

Never lift any object which is insecure or out of balance.

(7) Never use hoist to end or side pull a load. (Illust. 3)

(8) Never wrap around and hook back the load chain as a sling to lift a load. (Illust. 4)

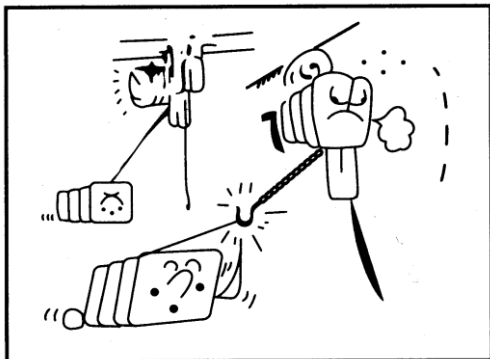

Illust. 3

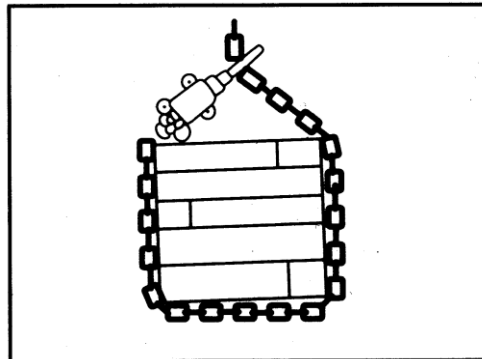

Illust. 4

**! WARNING**

Do not use the hoist chain as a welding electrode.

**! DANGER**

Never stand under a raised load (Illust. 5)

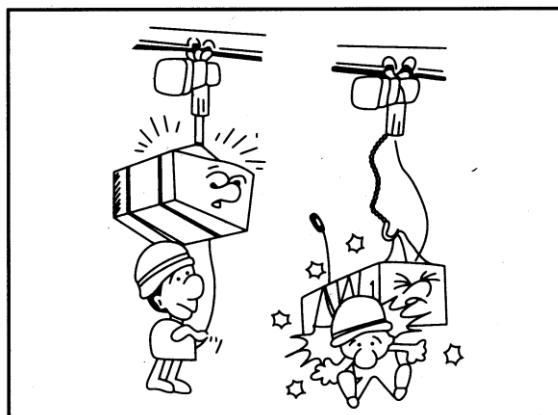

Illust. 5

(9) Lifting must always be personally attended, never leave a raised load unattended.

(10) Over-capacity-load lifting is hazardous and should not be undertaken.

(11) Never lift a load when the load chain is twisted.

(12) Regularly inspect and check the condition of load chain. Do not operate with damaged chain.

(13) Bucket Specifications:

Bucket No.	Key No.	Bucket Size (mm)	Fall No.	Lift (m)	Chain (mm)	Material
BD1#	208813	90×130×185	1	3~6	φ 4.0	Polyethylene
			2	3		
BD2#	201386	120×160×230	1	7~12	φ 4.0	Polyethylene
			2	4~6		
BD3#	201606	130×170×260	1	13~18	φ 4.0	Canvas
			2	7~9		
BD4#	201607	130×170×310	1	19~24	φ 4.0	Canvas
			2	10~12		
BD5#	201608	130×170×390	1	25~30	φ 4.0	Canvas
			2	13~15		
BD6#	201609	130×170×470	1	31~36	φ 4.0	Canvas
			2	16~18		
BD7#	201610	130×170×550	1	37~42	φ 4.0	Canvas
			2	19~21		
BD8#	201611	130×170×645	1	43~50	φ 4.0	Canvas
			2	22~25		

## 4. INSTALLATION

### 4.1 Unpacking Information

After removing the hoist from its packing box, carefully inspect the external condition of the electrical cables, contactor, gear box and motor casing for damage.

Check and ensure that these items are present.

Each hoist is supplied as standard with the following accessories.

1. Chain bucket	1 piece
2. Power cable	3 meters
3. Separated control cable with PBS and male plug	1 set

Table. 4-1

### 4.2 Voltage

#### CAUTION

If power supply deviates from standard by more than  $\pm 10\%$ , abnormal operation or damage to the motor may result. It is imperative to ensure correct voltage supply before commencing operation.

## 4.3 Installation

### **! WARNING**

Connection to power supply before installation procedures having been completed is strictly prohibited.

The equipment safety earth connection on the plug must NEVER be removed.

(1) Prior to installation check and ensure that the top hook assembly is securely attached to the hoist by means of the lock bolt (key No.56, page.22).

NOTE: If the hoist is to be installed under a trolley, remove the top hook and install the trolley on the hoist.

(2) Assemble chain bucket.

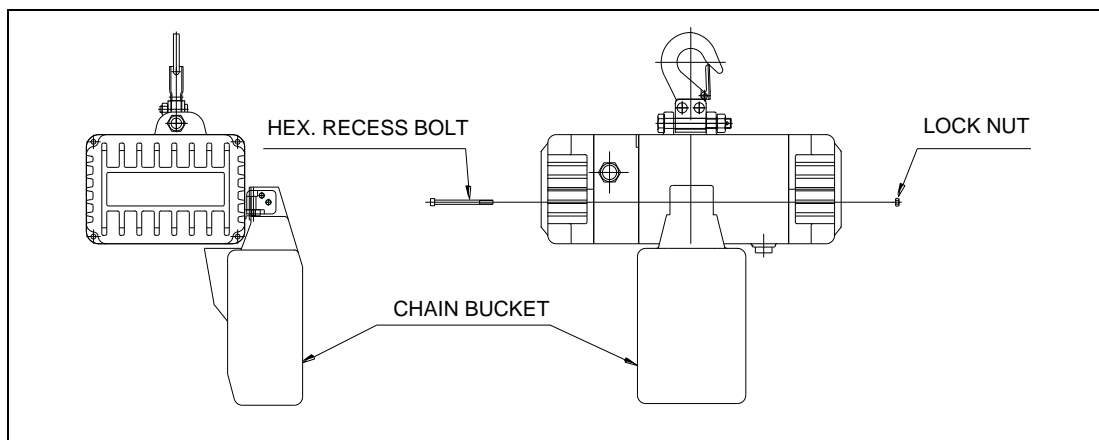



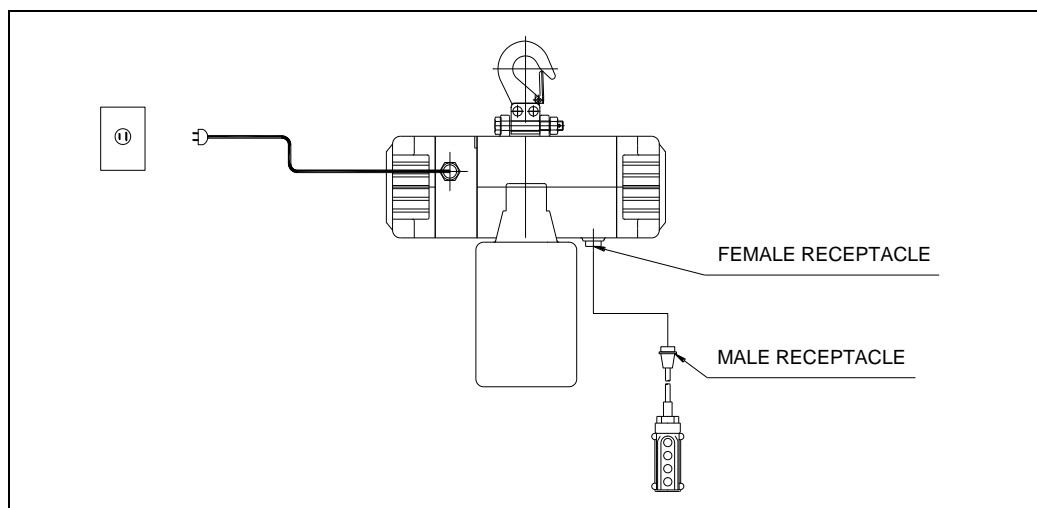

Illust. 6

(3) Plug power supply to hoist and operate the push button switch. This operation must be carried out by a trained person.



Illust. 7

#### (4) Operation Test

- (a) Firmly push  switch button to lower load chain until the chain end buffer touches the limit switch. Power should be cut off automatically.
- (b) Firmly push  switch button to check the collection of load chain into chain bucket.
- (c) Check load chain lubrication. (It has been lubricated at our works, but the lubricant may dry out during transportation) Any readily available lubricant is recommended. It is further advisable to keep a small amount of lubricant in chain bucket to allow chain in oil bath.
- (d) Check the emergency stop device function :  
While holding down either  or  button on the push button switch, push the emergency stop button. Check that the hook stops when the emergency stop button is pushed. Also, check the hoist does not move in response to the push button switch. Finally, check that the emergency stop device pops out when turned to the right and that operation can be resumed thereafter. If the equipment fails to pass another above checks, check the wiring and automatic locking function of the emergency stop device.

## 5. OPERATION

After running test and checks have been completed, the hoist will be ready for normal operation.

### **WARNING**

Since dealing with heavy loads may involve unexpected danger all of the "SAFETY RULES" (Ref 3.) must be followed and the operator must be aware of the following points while using the hoist.

- (1) On connection of power supply allow 15 seconds to initiate start up.
- (2) The operator must have a clear and unobstructed view of the entire working area before operating the hoist.
- (3) The operator must check that the entire working area is safe and secure before operating the hoist.
- (4) When using the hoist with a plain trolley, the operator must take care to prevent excessive load swinging by sympathetic push trolley movements.

## 6. MAINTENANCE AND INSPECTION

### **DANGER**

Do not perform maintenance on the hoist while it is carrying a load except monthly checking for the brake, limit switch or slip clutch.

### **DANGER**

Before performing maintenance do not forget to affix tags to the power source and the push button switch reading : "DANGER", "EQUIPMENT BEING REPAIRED".

### 6.1 Maintenance

- (1) Check the level of gear box lubricant after first 100 hours of operation, thereafter every 3 months and lubricant accordingly. Lubricant use ISO VG460 or equivalent.
- (2) Always keep the hoist unit dry and never misuse it in a manner likely to reduce its durability.
- (3) When it is necessary to keep the unit outdoors, a protective covering should be fitted.

### 6.2 Inspection

- (1) Daily inspection: Before starting daily operation, check the following,
  - (a) Correct power supply.
  - (b) "Up" , "Down" and "Emergency stop" (where fitted) test runs under no load.
  - (c) Correct motor performance.
  - (d) No abnormal or excessive noise.
  - (e) No malfunction of the bottom hook safety latch.
  - (f) Proper function of moving/turning parts, limit switches and brake.
  - (g) Well lubricated load chain.

#### (2) Monthly inspection

### **WARNING**

Always use the hoist manufacture's recommended parts when repairing a hoist.

(a) Load chain:

Distorted, elongated or worn chain link will not sit properly on the load sprocket wheel and may cause chain breakage and/or damage to hoist unit. To ensure safe and efficient operation, the chain links must be checked for their pitch (inside length, inside width) and outside width monthly according to following table.

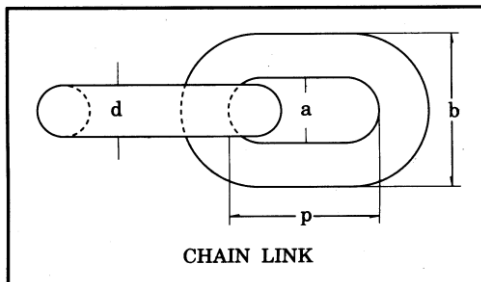

Dia-Meter (mm) (d)	Inside Length (mm) (p)	Inside Width (mm) (a)	Outside Width (mm) (b)
4.0	12.0	5.0	14.0

## Chain Gauge — Wear and Stretch Measuring

- (1) The chain gauge is useful and convenience for measuring.
- (2) Please use a chain gauge to measure the chain pitch and diameter, such as illustrations (1) and (2).
- (3) Every chain ring must be measured, and the chain must be replaced when one of chain ring is wear or stretch.
- (4) It will be a cutting-out possibility if you use a chain fall either wear or stretch during operation.
- (5) Do not replace a chain fall by yourself and do please contact specific either service centers or contractors to help you out.
- (6) The chain fall must be replaced whole instead of a partial part.
- (7) The load sheave, regulator, and chain compressing wheel must be replaced the same time as you do a second time replacement.

### Remark :

- (1) Chain must be perfect condition without any defects and attachments.

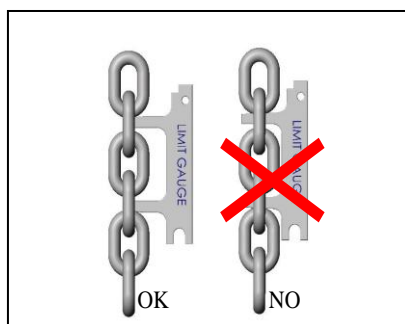

Illustration (1)  
Chain pitch measure

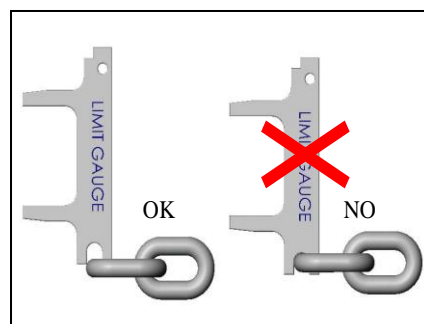
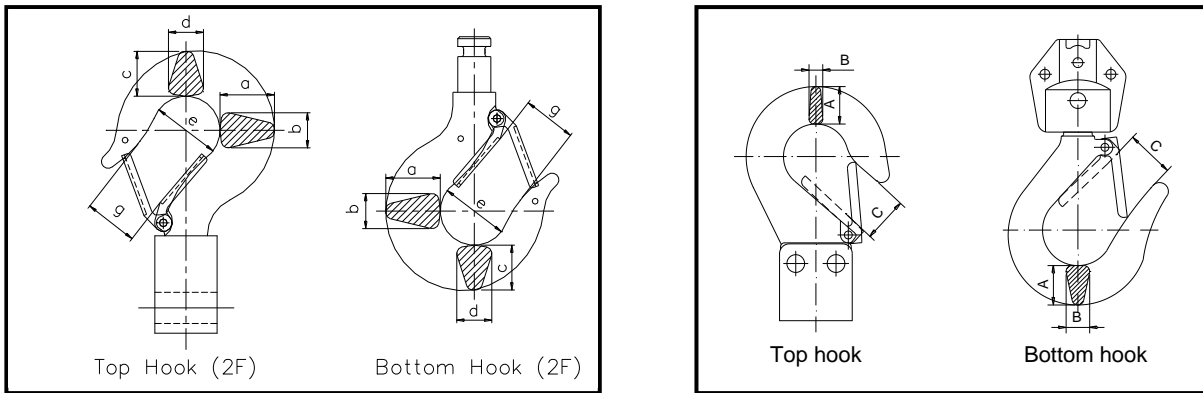

Illustration (2)  
Diameter measure

(b) Load chain:

Check hook with care. If hook shows crack deformation or wear in excess of 5% of its original size, it should be replaced. (Ref. following table)



Fall	Hook	Dimensions (mm)					
		a	b	c	d	e	g
1F	Top hook	19	7	23			
	Bottom hook	20	12	25			
2F	Top hook	28	18	23	18	35	25
	Bottom hook	28	18	23	18	35	25

(3) Annual inspection

**⚠ WARNING**  
Your dealer should be asked to perform this inspection.

- (a) check gearing for any excessive wear or damage.
- (b) Replace gear box lubricant completely (500C.C ± 10%) as following table for your reference.

※Table of recommended oils according to DIN 51354

ISO-VGDIN 51519 viscosity At 40°C mm <sup>2</sup> /s (cST)	Approximate viscosity of the VG Categories 50°C mm <sup>2</sup> /s (cST)	ARAL	BP	ESSO	MOBIL OIL
VG460	251	Aral Degol BG 460-BMB 460	BP Energol GR-XP 460	Spartan EP-460	Mobilgear 634

ISO-VGDIN 51519 Viscosity at 40°C mm <sup>2</sup> /s (cST)	Approximate viscosity of the VG Categories 50°C mm <sup>2</sup> /s (cST)	SHELL	TEXACO	I..P.	AGIP
VG460	251	Omala oil 460	Meropa 460	Mellana 460	Blasia 460

- (c) Check brake lining and ratchet pawl for any wear or damage.
- (d) Check operation of pawl spring.
- (e) After reassembly of above check, lifting a load several times to ensure good performance of the hoist before starting duty operation.



# 7. TROUBLESHOOTING

## 7.1 Wiring Diagrams

- (1) 100V~110V — 1Ph — 50/60Hz power supply (With Emergency Stop)..... 17
- (2) 200V~240V — 1Ph — 50/60Hz power supply (With Emergency Stop)..... 18

The above listed wiring diagram for reference only.

The end user should refer to the wiring diagram stuck to the inside cover of electric housing.

Our electric specifications can be done according to following.

- (a) 1 — Phase
- (b) 50Hz or 60Hz
- (c) 100V~110V or 200V~240V

## Warranty Details

1. Warranty Period : One year for Mechanical Spare Parts after purchase the product.
2. Non-Warranty Scope:
  - a. Electrical Spare Parts (ex. Contactor, Pendant, Phase Error Relay, etc.)
  - b. Expense Spare Parts (ex. Chain Bucket, Brake Lining, etc.)
  - c. Damage caused by unsuitable operation.  
(ex. Galvanize plant, Chemical Plant, Dye-work, etc. )
  - d. Damage caused by operating on the wrong electric voltage.
  - e. Damage caused by user amend the product.
  - f. Damage caused by natural disaster.
3. Warranty Scope shall be permitted by Cheng Day Machinery and Within One Year of damaged  
Mechanical Spare Parts Repair and Replacement.  
(circumstance stated in detail No. 2 are not included.)

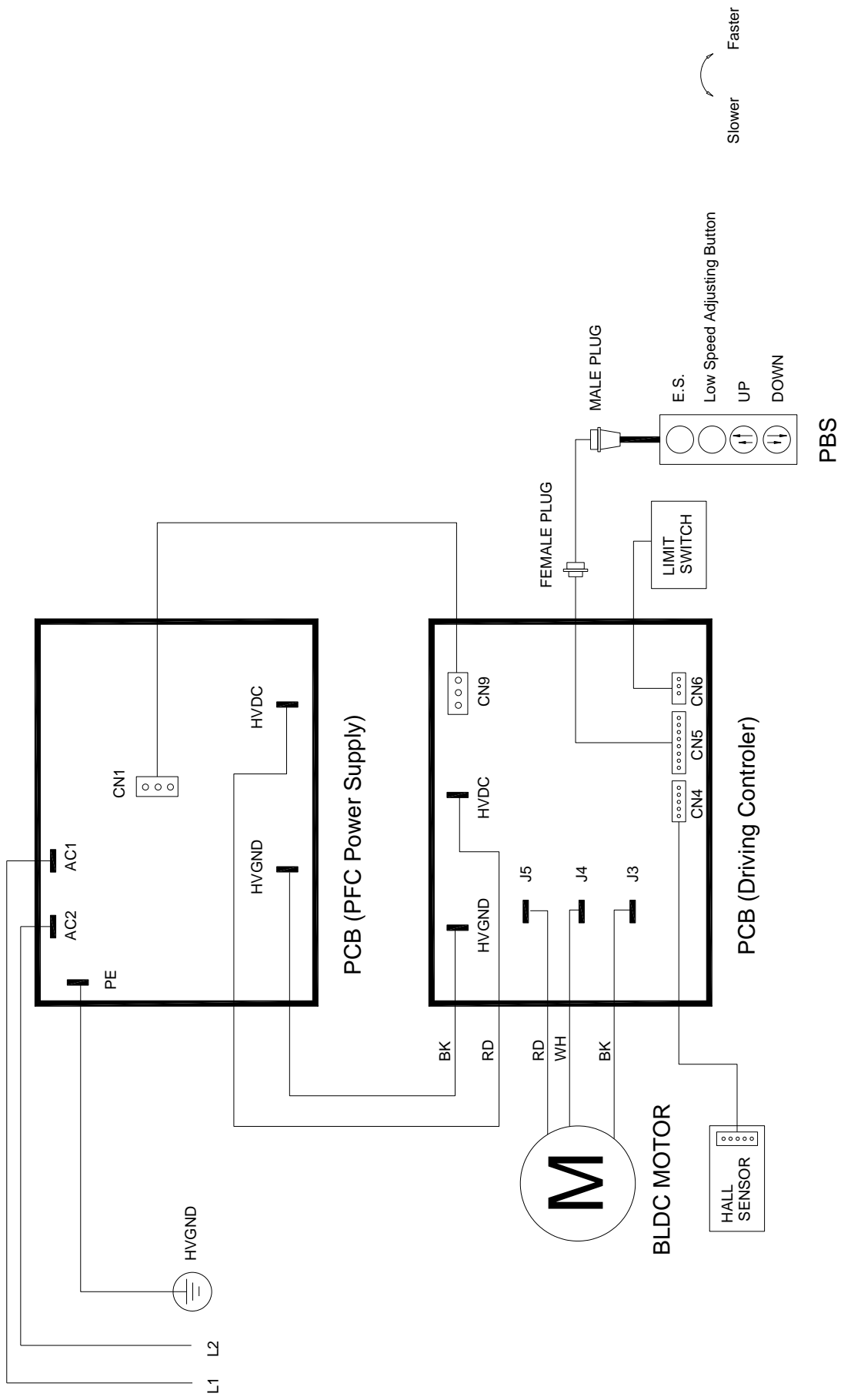

ELECTRIC POWER SUPPLY	SINGLE PHASE, 100~110V, 50/60Hz
CONTROL VOLTAGE	DC 18V

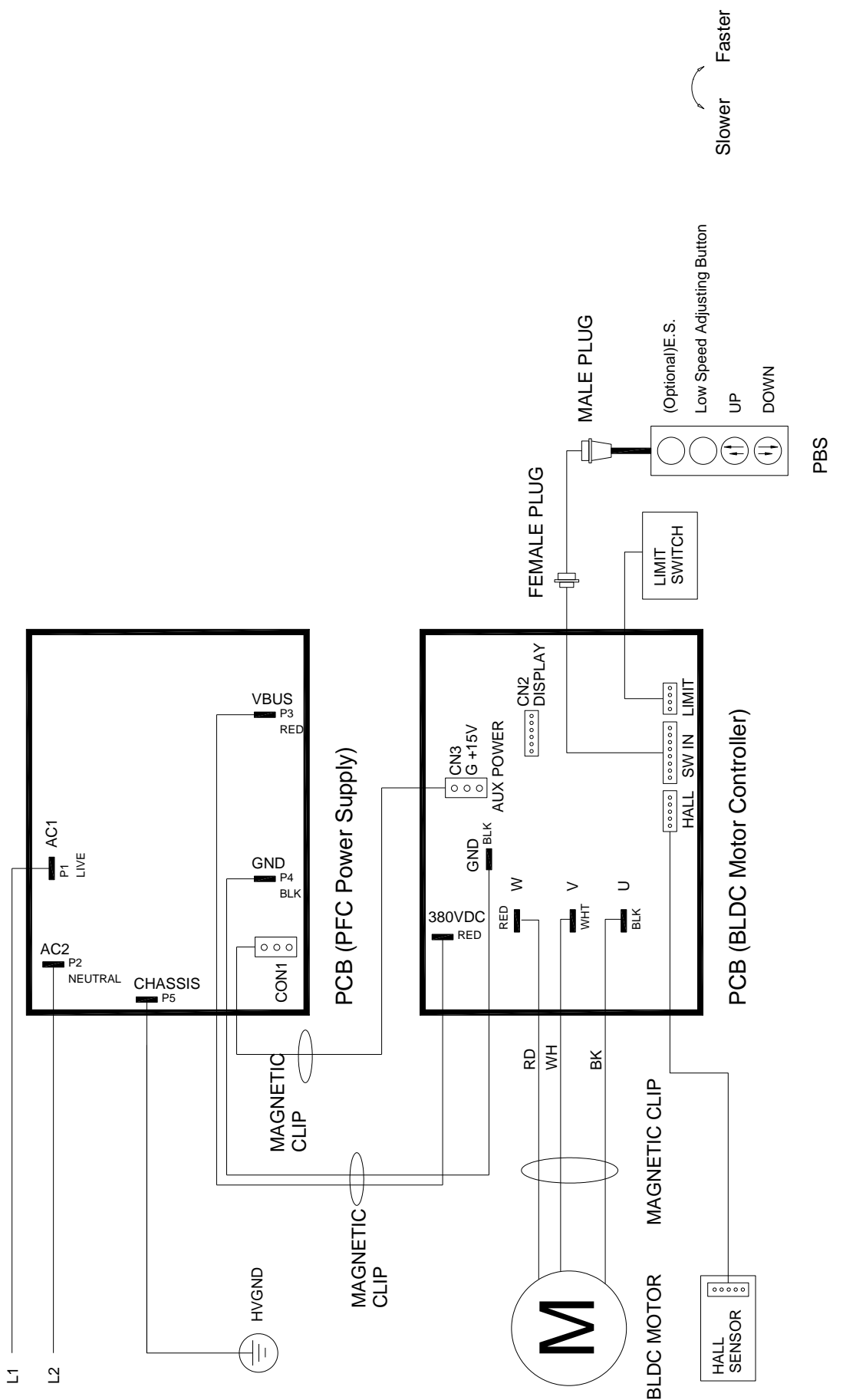

ELECTRIC POWER SUPPLY	SINGLE PHASE, 200~240V, 50/60HZ
CONTROL VOLTAGE	DC 18V

D10016A

## 7.2 Troubleshooting and Remedial Action

SITUATION	CAUSE	REMEDY
Hoist will not operate	(1) Phase error relay operated due to incorrect phase connections.	Check the phase connections of controller & the wire's color of BLDC motor for correct Ref. Page 16 or 17
	(2) Blown power fuse or tripped power circuit breaker.	Check supply requirements and refuse/reset breaker to meet requirements Contact your authorized "U-MEGA" dealer- if high voltage fuse was blown
	(3) Blown control circuit fuse.	Check fuse for correct rating and replace
	(4) Broken/disconnected power or control circuit wire.	Locate and repair/reconnect ( take the power supply away until 10 min. later )
	(5) Low supply voltage	Check if 10% reduction in voltage, have mains supply checked
	(6) Motor hums but does not rotate	Check motor-insulate and wire connection
	(7) Emergency stop button release pushed	Check the cause as necessary
	(8) The button of PBS is fixed	Release the button of PBS
	(9) The button or Elect. wire of PBS is broken	Replace or repair it ( take the power supply away until 5 min. later )
	(10) Broken/is connected limit switch	Locate and repair/reconnect
Brake slips	Abrasion of motor brake	Replace
Hoist runs but does not lift	(1) Clutch slipping	Contact your authorized " U-MEGA " dealer — this adjustment needs to be carried out on a test rig
Abnormal sound on load chain/chain sprocket	(1) Chain dry (2) Worn chain sprocket	Lubricate Replace load chain and chain sprocket
Electric shock	(1) Poor earth connection (2) Accumulated foreign matter/ moisture on electrical parts	Provide correct earth connection Remove foreign matter/dry electrical parts
Oil leak	(1) No oil plug (2) Loose fitting of oil plug (3) No plug packing (4) Worn or deteriorated oil packing	Attach the normal oil plug Fasten the plug tightly Attach normal packing Attach the new packing

# BLFD-008,012,016,024 BODY EXPLOSION

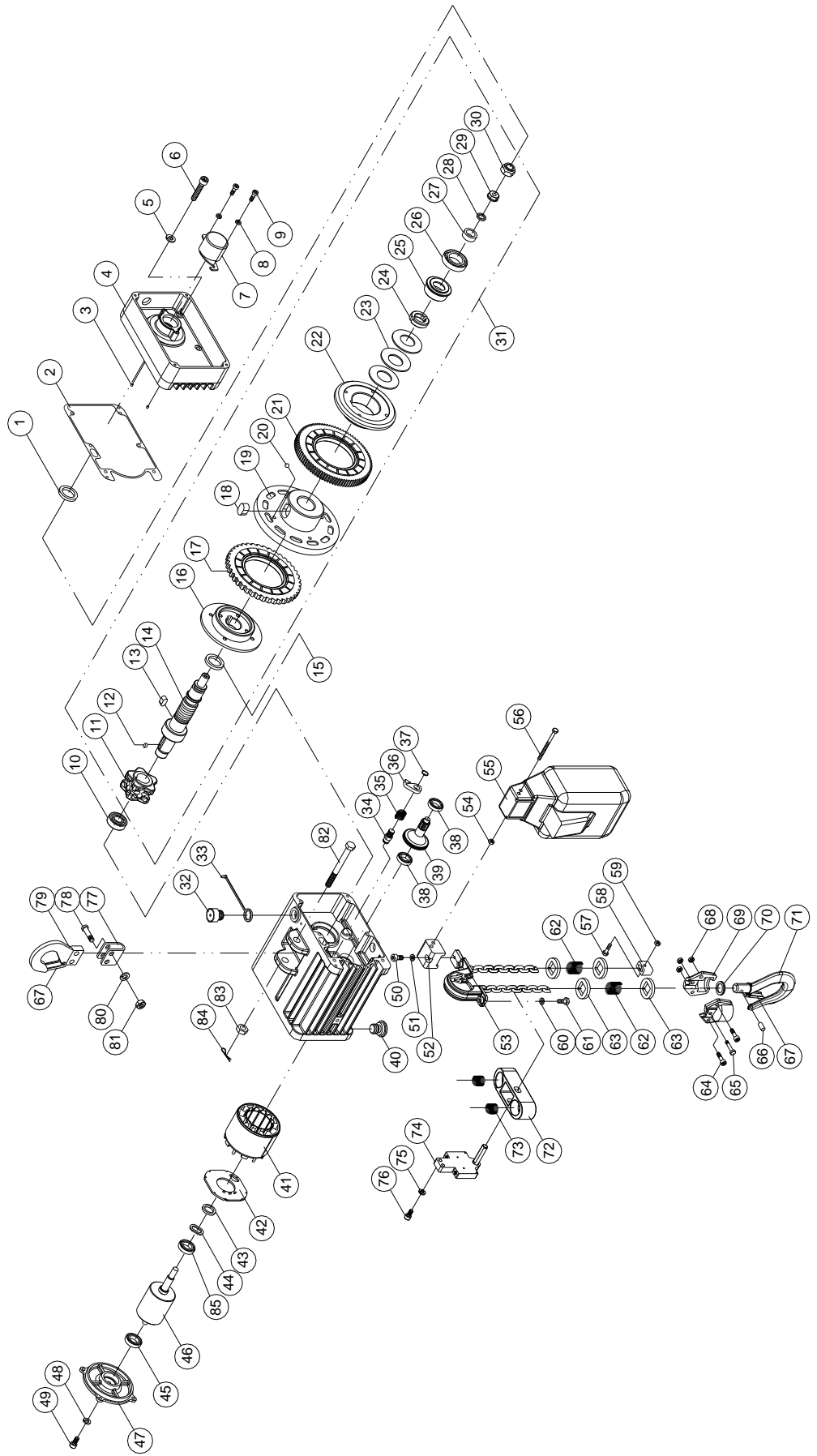

## BLFD-008,012,016,024 BODY PARTS B.O.M.

KEY NO.	PARTS CODE	DESCRIPTION	Q'TY REQ'D EACH UNIT			
			008	012	016	024
1	400943	Oil Seal < Ø25 × Ø35 × 5t >	1	1	1	1
2	402586	Gasket #40	1	1	1	1
3	400615	Parallel Pin < Ø5 × 12L >	2	2	2	2
4	208815	Gearbox	1	1	1	1
5	400094	Spring Washer <M6 >	6	6	6	6
6	400418	Hex. Recess Bolt <M6 × 1.0 × 30L >	6	6	6	6
7	208836	Cover	1	1	1	1
8	400661	Flat Washer <M4 >	2	2	2	2
9	408394	Cross Headed Screw <M4 × 0.7 × 6L >	2	2	2	2
10	400110	Bearing <6202 ZZ >	1	1	1	1
11	208834	Load Sheave	1	1	1	1
12	405924	Key < t5 × 5 × 20L >	1	1	1	1
13	400962	Key < t6 × 6 × 12L >	1	1	1	1
14	201219	Sheave Spindle < Ø30 × 145L >	1	1	1	1
15	400934	Oil Seal < Ø30 × Ø50 × 8t >	1	1	1	1
16	201321	Brake Body < Ø83 × Ø20 × 17.5L >	1	1	1	1
17	208843	Ratchet Ass'y	1	1	1	1
18	405944	Key < t10 × 8 × 16L >	1	1	1	1
19	201340	Brake Bushing < Ø105 × 27.85L >	1	-	1	-
	201327	Brake Bushing < Ø105 × 27.75L >	-	1	-	1
20	400289	Ball	3	3	3	3
21	268132	4th Gear Ass'y <M1.25 × 83T >	1	-	1	-
	201329	4th Gear Ass'y <M1.25 × 89T >	-	1	-	1
22	201323	Brake Flange < Ø87 × 19.1L >	1	1	1	1
23	207118	Disc Spring	3	3	-	-
	200404		-	-	3	3
24	200272	Load Brake Gear Spacer	2	2	2	2
25	201325	Bush < Ø34 × 10L >	1	1	1	1
26	400125	Bearing <6003 >	1	1	1	1
27	200402	Oil Bush < Ø25 × Ø17 × 9L >	1	1	1	1
28	400226	O-Ring < Ø12 × Ø17 × 2.5 >	1	1	1	1
29	200407	Flange Nut <M10 × 1.5 × 8L >	1	1	1	1
30	400089	Lock Nut <M10 × 1.5 >	1	1	1	1
31	268221	Over Load Ass'y	1	-	-	-
	268222		-	1	-	-
	201253		-	-	1	-
	201200		-	-	-	1

## BLFD-008,012,016,024 BODY PARTS B.O.M.

KEY NO.	PARTS CODE	DESCRIPTION	Q'TY REQ'D EACH UNIT			
			008	012	016	024
32	200926	Hex. Oil Plug	1	1	1	1
33	200927	Air Plug	1	1	1	1
34	200416	Ratchet Pawl Pin <d14×26L>	2	2	2	2
35	408512	Ratchet Pawl Spring	2	2	2	2
36	200415	Ratchet Pawl	2	2	2	2
37	400907	Retaining Ring <S-11>	2	2	2	2
38	407845	Bearing<6000>	2	2	2	2
39	201320	2nd & 3rd Gear Set	1	-	1	-
	200417		-	1	-	1
40	300523	Oil plug <Philips Machine Screw Ass'y >	1	1	1	1
41	106120	Stator Ass'y <300W>	1	1	-	-
	106109	Stator Ass'y <600W>	-	-	1	1
42	106118	Hall Sensor Plate	1	1	1	1
43	400945	Oil Seal< Ø12×Ø25×7t>	1	1	1	1
44	400863	Wave Washer <6201>	1	1	1	1
45	405569	Bearing <6201ZZ>	1	1	1	1
46	106125	Rotor <300W>	1	1	-	-
	106108	Rotor <600W>	-	-	1	1
47	106111	Motor End Cover	1	1	1	1
48	400093	Spring Washer <M5>	4	4	4	4
49	400003	Hex. Recess Bolt <M5×0.8×16L>	4	4	4	4
50	408396	Hex. Recess Bolt <M5×0.8×10L>	1	1	1	1
51	400093	Spring Washer <M5>	1	1	1	1
52	208824	Chain Bucket Connector	1	1	1	1
53	208816	Chain Guide	1	1	1	1
54	400646	Lock Nut <M5>	2	2	2	2
55	208813	Chain Bucket <No.1>	1	1	1	1
56	408486	Hex. Recess Bolt <M5×0.8×70L>	2	2	2	2
57	200445	Lock Pin < Ø10×25.5L>	1	1	1	1
58	200441	Chain Stopper <24×19×13.5>	1	1	1	1
59	400646	Lock Nut <M5>	1	1	1	1
60	400094	Spring Washer <M6>	2	2	2	2
61	400006	Hex. Recess Bolt <M6×1.0×16L>	2	2	2	2
62	408485	Spring	2	2	2	2
63	200442	Buffer Steel Plate <t4×25.5>	4	4	4	4

**BLFD-008,012,016,024 BODY PARTS B.O.M.**

KEY NO.	PARTS CODE	DESCRIPTION	Q'TY REQ'D EACH UNIT			
			008	012	016	024
64	408329	Hex. Recess Bolt <M5 × 0.8 × 20L>	2	2	2	2
65	200445	Lock Pin < Ø10 × 25.5L>	1	1	1	1
66	407463	Parallel Pin < Ø8 × 25L>	1	1	1	1
67	200480	Safe Latch Ass'y	2	2	2	2
68	400646	Lock Nut <M5>	3	3	3	3
69	201371I	Bottom Hook Cover Set	2	2	2	2
70	400830	Thrust Bearing	1	1	1	1
71	201372I	Bottom Hook	1	1	1	1
72	208857	Collision Block	1	1	1	1
73	408588	Collision Block Spring	2	2	2	2
74	208818	Limit Switch Ass'y	1	1	1	1
75	400093	Spring Washer <M5>	2	2	2	2
76	400417	Hex. Recess Bolt <M5 × 0.8 × 20L>	2	2	2	2
77	200432	Top Hook Suspension <t20 × 37 × 39L>	1	1	1	1
78	200433	Top Hook lock bolt <Ø12 × 29.5L>	2	2	2	2
79	200456	Top Hook	1	1	1	1
80	400095	Spring Washer <M8>	2	2	2	2
81	400088	Lock Nut <M8 × 1.25>	2	2	2	2
82	208827	Lock Bolt < Ø12/M12 × 1.75 × 85L>	1	1	1	1
83	400084	Hex. Nut <M12 × 1.75>	1	1	1	1
84	400610	Cotter Pin <Ø3 × 30L>	1	1	1	1
85	405641	Bearing <6201 2RS>	1	1	1	1



# BLFD-032,048 BODY EXPLOSION

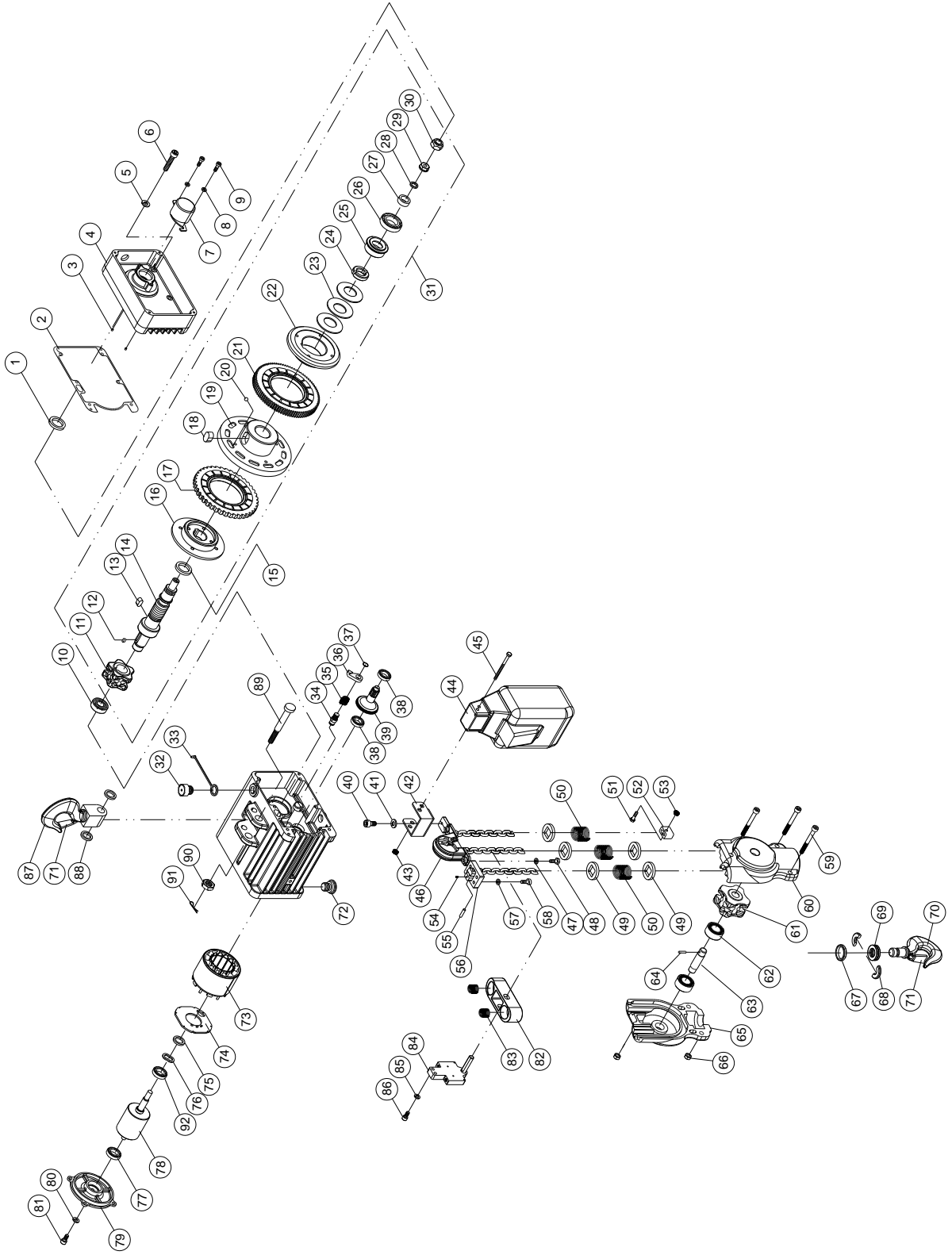

## BLFD-032,048 BODY PARTS B.O.M.

KEY NO.	PARTS CODE	DESCRIPTION	Q'TY REQ'D EACH UNIT	
			032	048
1	400943	Oil Seal < Ø25 × Ø35 × 5t >	1	1
2	402586	Gasket #40	1	1
3	400615	Parallel Pin < Ø5 × 12 >	2	2
4	208815	Gearbox	1	1
5	400094	Spring Washer <M6 >	6	6
6	400418	Hex. Recess Bolt <M6 × 1.0 × 30L >	6	6
7	208836	Cover	1	1
8	400661	Flat Washer <M4 >	2	2
9	408394	Cross Headed Screw <M4 × 0.7 × 6L >	2	2
10	400110	Bearing <6202 ZZ >	1	1
11	208834	Load Sheave	1	1
12	405924	Key < t5 × 5 × 20L >	1	1
13	400962	Key < t6 × 6 × 12L >	1	1
14	201219	Sheave Spindle < Ø30 × 145L >	1	1
15	400934	Oil Seal < Ø30 × Ø50 × 8t >	1	1
16	201321	Brake Body < Ø83 × Ø20 × 17.5L >	1	1
17	208843	Ratchet Ass'y	1	1
18	405944	Key < t10 × 8 × 16L >	1	1
19	201340	Brake Bushing < Ø105 × 27.85L >	1	-
	201327	Brake Bushing < Ø105 × 27.75L >	-	1
20	400289	Ball	3	3
21	268132	4th Gear Ass'y <M1.25 × 83T >	1	-
	201329	4th Gear Ass'y <M1.25 × 89T >	-	1
22	201323	Brake Flange < ø 87 × 19.1L >	1	1
23	200404	Disc Spring	3	3
24	200272	Load Brake Gear Spacer	2	2
25	201325	Bush < Ø34 × 10L >	1	1
26	400125	Bearing <6003 >	1	1
27	200402	Oil Bush < Ø 25 × Ø 17 × 9L >	1	1
28	400226	O-Ring < Ø 12 × Ø17 × 2.5 >	1	1
29	200407	Flange Nut <M10 × 1.5 × 8L >	1	1
30	400089	Lock Nut <M10 × 1.5 >	1	1
31	201253	Over Load Ass'y	1	-
	201200		-	1
32	200926	Hex. Oil Plug	1	1
33	200927	Air Plug	1	1
34	200416	Ratchet Pawl Pin < d14 × 26L >	2	2
35	408512	Ratchet Pawl Spring	2	2

## BLFD-032,048 BODY PARTS B.O.M.

KEY NO.	PARTS CODE	DESCRIPTION	Q'TY REQ'D EACH UNIT	
			032	048
36	200415	Ratchet Pawl	2	2
37	400907	Retaining Ring <S-11>	2	2
38	407845	Bearing <6000>	2	2
39	201320	2nd & 3rd Gear Set	1	-
	200417		-	1
40	408396	Hex. Recess Bolt <M5 × 0.8 × 10L>	1	1
41	400093	Spring Washer <M5>	1	1
42	208824	Chain Bucket Connector	1	1
43	400646	Lock Nut <M5>	2	2
44	208813	Chain Bucket <No.1>	1	1
45	408486	Hex. Recess Bolt <M5 × 0.8 × 70L>	2	2
46	208816	Chain Guide	1	1
47	400094	Spring Washer <M6>	2	2
48	400006	Hex. Recess Bolt <M6 × 1.0 × 16L>	2	2
49	200442	Buffer Steel Plate <t4 × 25.5>	6	6
50	408485	Spring	3	3
51	200445	Lock Pin < Ø10 × 25.5L>	1	1
52	200441	Chain Stopper <24 × 19 × 13.5>	1	1
53	400646	Lock Nut <M5>	1	1
54	408407	Threaded Stud <M4 × 0.7 × 4L>	1	1
55	407462	Parallel Pin <Ø5 × 25L>	1	1
56	208839	Load Bracket	1	1
57	400093	Spring Washer <M5>	4	4
58	405019	Hex. Recess Bolt <M5 × 0.8 × 15L>	4	4
59	408329	Hex. Recess Bolt <M5 × 0.8 × 20L>	3	3
60	207069	Bottom Block Cover A	1	1
61	200361	Sprocket	1	1
62	408058	Needle Bearing <HK1412>	2	2
63	200322	Sprocket Axle	1	1
64	400295	Spring Pin <ø3 × 10L>	1	1
65	207071	Bottom Block Cover B	1	1
66	400646	Nylon Nut<M5>	3	3
67	200221	End Spacer	1	1
68	200212	Half Spacer	2	2
69	408057	Thrust Bearing <51103>	1	1
70	200367	Bottom Hook Ass'y	1	1
71	400300	Safety Latch Ass'y	2	2
72	300523	Oil plug <Philips Machine Screw Ass'y >	1	1

# BLFD-032,048 BODY PARTS B.O.M.

KEY NO.	PARTS CODE	DESCRIPTION	Q'TY REQ'D EACH UNIT	
			032	048
73	106109	Stator Ass'y <600W>	1	1
74	106118	Hall Sensor Plate	1	1
75	400945	Oil Seal < Ø12 × Ø25 × 7t>	1	1
76	400863	Wave Washer <6201>	1	1
77	405569	Bearing <6201ZZ>	1	1
78	106108	Rotor <600W>	1	1
79	106111	Motor End Cover	1	1
80	400093	Spring Washer <M5>	4	4
81	400003	Hex. Recess Bolt <M5 × 0.8 × 16L>	4	4
82	208857	Collision Block	1	1
83	408588	Collision Block Spring	2	2
84	208818	Limit Switch Ass'y	1	1
85	400093	Spring Washer <M5>	2	2
86	400417	Hex. Recess Bolt <M5 × 0.8 × 20L>	2	2
87	208845	Top Hook Ass'y	1	1
88	208840	Washer	2	2
89	208841	Lock Bolt < Ø15/M12 × 1.75x85L>	1	1
90	400084	Hex. Nut <M12 × 1.75>	1	1
91	400610	Cotter Pin <Ø3 × 30L>	1	1
92	405641	Bearing <6201 2RS>	1	1

## ELECTRIC EXPLOSION

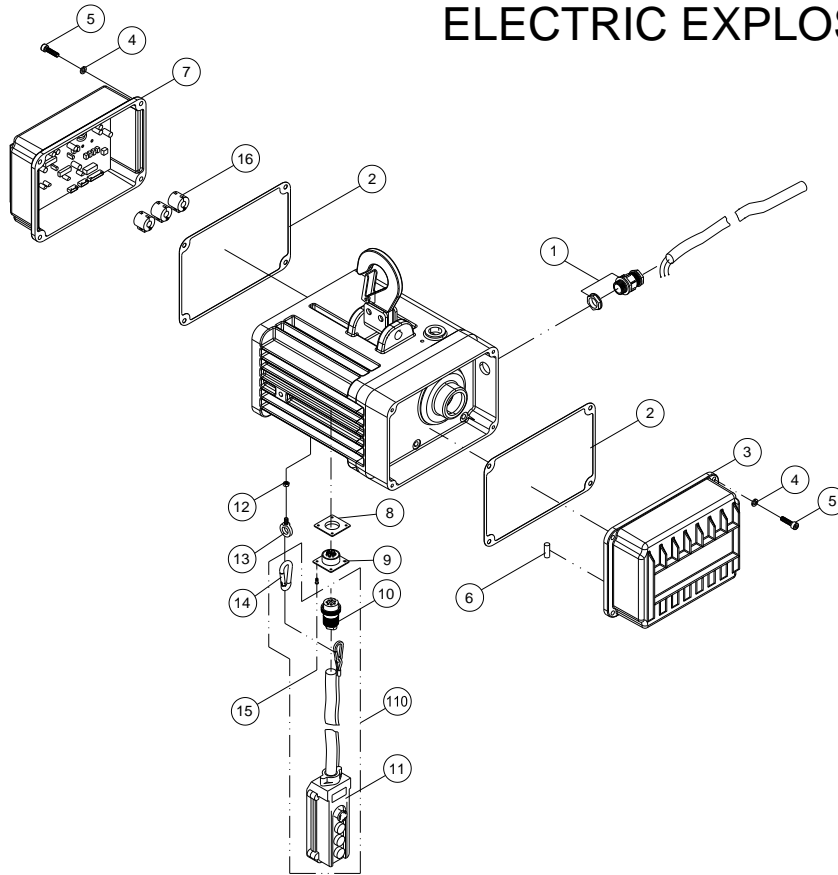

## ELECTRIC PARTS B.O.M.

KEY NO.	PARTS CODE	DESCRIPTION	Q'TY REQ'D EACH UNIT
			100V~240V
1	400223	Cable Gland <M16>	1
2	402587	Gasket #41	2
3	302388	PFC Power Supply Ass'y	1
4	400854	Spring Washer <M5>	8
5	408608	Hex. Recess Bolt <M5 × 0.8 × 16L>	8
6	302283	Fuse <6 × 30-20A>	1
7	302389	DC Motor Controller Ass'y	1
8	402588	Gasket #42	1
9	300615	Female Receptacle	1
10	300616	Male Receptacle	1
11	300610	Push Button Switch	1
12	400087	Nut <M6x1.0>	1
13	404803	Eye Bolt < M6x1.0>	1
14	400841	Shackle	1
15	408601	Cross Headed Screw <M3 × 0.5 × 10L>	4
16	301849	Magnetic Clip	3

**VERIFICATION OF COMPLIANCE**  
to the requirements of  
**Machinery Directive 2006/42/EC**

Verification Report No. : RA/2016/90004C-01  
 Representative Model : NHD-200-2  
 Series Model(s) : NHTD-025-1, -050-2, -050-1, -100-2, -100-1, -200-2;  
 NHD-025-1, -050-2, -050-1, -100-2, -100-1;  
 NT-050-1, -050-2, -100-1, -100-2, -200-2;  
 NTD-050-1, -050-2, -100-1, -100-2, -200-2;  
 SH-025-1, -050-1, -100-1, -200-2; WNH-012, -025, -050, -100;  
 WNT-012, -025, -050, -100; BLFD-008, -012, -016, -024, -032, -048  
 Product Name : Electric Chain Hoist and Trolley  
 Applicant : Cheng Day Machinery Works Co., Ltd.  
 Address of Applicant : No. 173, Wen Chiu Rd., Dajia Dist., Taichung City 437, Taiwan.  
 TCF Number : CHENGDAY(UMEGA)-2016-B1  
 Date of Issue : September 12, 2016  
 Date of Expiry : September 12, 2021  
 Applicable Standard(s) : EN ISO 12100:2010, EN 14492-2 :2006+A1 :2009/AC :2010

**Conclusion**

Based upon a review of the Technical Construction File, the apparatus is deemed to meet the requirements of the above standard(s) and hence fulfill the requirements of:

**Machinery Directive 2006/42/EC**

*Note : This verification is only valid for the apparatus and configuration described and in conjunction with the technical data detailed above.*

*The CE mark as shown below can be used, under the responsibility of the manufacture, after completion an EC Declaration of Conformity and compliances with all relevant EC Directives*

**Authorized Signatory:**



**SGS TAIWAN LTD.**  
Jason Lin  
Technical Manager

This document is issued by the Company subject to its General Conditions of Service printed overleaf, available on request or accessible at <http://www.sgs.com/en/Terms-and-Conditions.aspx> and, for electronic format documents, subject to Terms and Conditions for Electronic Documents at <http://www.sgs.com/en/Terms-and-Conditions/Terms-e-Document.aspx>. Attention is drawn to the limitation of liability, indemnification and jurisdiction issues defined therein. Any holder of this document is advised that information contained hereon reflects the Company's findings at the time of its intervention only and within the limits of Client's instructions, if any. The Company's sole responsibility is to its Client and this document does not exonerate parties to a transaction from exercising all their rights and obligations under the transaction documents. This document cannot be reproduced except in full, without prior written approval of the Company. Any unauthorized alteration, forgery or falsification of the content or appearance of this document is unlawful and offenders may be prosecuted to the fullest extent of the law. Unless otherwise stated the results shown in this test report refer only to the sample(s) tested



SGS Reference No: RA/2016/90005C-01

Page 1 of 1

## VERIFICATION OF COMPLIANCE

Verification Report No. : RA/2016/90005C-01  
 Representative Model : NHD-200-2  
 Series Model(s) : NHTD-025-1, -050-2, -050-1, -100-2, -100-1, -200-2;  
 NHD-025-1, -050-2, -050-1, -100-2, -100-1;  
 NT-050-1, -050-2, -100-1, -100-2, -200-2;  
 NTD-050-1, -050-2, -100-1, -100-2, -200-2;  
 SH-025-1, -050-1, -100-1, -200-2; WNH-012, -025, -050, -100;  
 WNT-012, -025, -050, -100; BLFD-008, -012, -016, -024, -032, -048  
 Product Name : Electric Chain Hoist and Trolley  
 Applicant : Cheng Day Machinery Works Co., Ltd.  
 Address of Applicant : No. 173, Wen Chiu Rd., Dajia Dist., Taichung City 437, Taiwan.  
 TCF Number : CHENGDAY(UMEGA)-2016-B1  
 Date of Issue : September 12, 2016  
 Applicable Standard(s) : EN 60204-32:2008

### Conclusion

Based upon a review of the Technical Construction File, the apparatus is deemed to meet the requirements of the above standard(s) and hence fulfill the requirements of:

### **Low Voltage Directive 2014/35/EU**

*Note : This verification is only valid for the apparatus and configuration described and in conjunction with the technical data detailed above.*

*The CE mark as shown below can be used, under the responsibility of the manufacture, after completion an EC Declaration of Conformity and compliances with all relevant EC Directives.*

### **Authorized Signatory:**



**SGS TAIWAN LTD.**  
Jason Lin  
Technical Manager

This document is issued by the Company subject to its General Conditions of Service printed overleaf, available on request or accessible at <http://www.sgs.com/en/Terms-and-Conditions.aspx> and, for electronic format documents, subject to Terms and Conditions for Electronic Documents at <http://www.sgs.com/en/Terms-and-Conditions/Terms-e-Document.aspx>. Attention is drawn to the limitation of liability, indemnification and jurisdiction issues defined therein. Any holder of this document is advised that information contained hereon reflects the Company's findings at the time of its intervention only and within the limits of Client's instructions, if any. The Company's sole responsibility is to its Client and this document does not exonerate parties to a transaction from exercising all their rights and obligations under the transaction documents. This document cannot be reproduced except in full, without prior written approval of the Company. Any unauthorized alteration, forgery or falsification of the content or appearance of this document is unlawful and offenders may be prosecuted to the fullest extent of the law. Unless otherwise stated the results shown in this test report refer only to the sample(s) tested.